



# Hiab XS 244 CLX Capacity 159,125 ft-lbs



Product brochure



# The tough and lightweight solution

## **The Hiab XS 244 is a midrange giant**

The Hiab XS 244 CLX is a crane that suits the needs of customers looking for a midrange solution. The crane is very robust and perfectly suited to tough and demanding tasks such as excavation. World-class engineering also provides you with the benefits of very low weight and impressive reach.

## **Designed for the tough jobs, every day**

Hiab designs cranes for rough and tough operation, and this crane is no exception. The crane is designed to be on the job, day in and day out, where it belongs; however, unscheduled servicing is necessary from time to time. In order to keep servicing time as short as possible, we have equipped the crane with JIC couplings and easily replaceable large slide pads. Before you know it, the crane is back at the jobsite, doing what it does best, creating solutions and versatility for your business.

# Hiab XS 244 CLX Capacity 159,125 ft-lbs

## Front runners in boom design

A Hiab crane is built to withstand extreme loading under all kinds of circumstances, in all field conditions. Keeping the boom reliable, tough and sturdy under extreme loading has made Hiab a world leader in crane boom engineering. Take a closer look at the crane, and you'll see a number of features that our customers benefit from.

## Hexagonal boom profile

The hexagonal profile used on Hiab booms is a ground-breaking design introduced by Hiab many years ago. It is now standard throughout the market for loader cranes. Even the smallest Hiab crane takes advantage of this design.

## X-function

Angling the outer boom upwards relative to the inner boom gives greater accessibility in confined spaces.



## High-torque slewing

A heavy-duty, high-torque slewing mechanism ensures safe and efficient operation, even on inclines or slopes.

## Load-holding valve

The load-holding valve is a combined hose-failure and load-holding valve, which is mounted on the cylinder.

## Hoses run internally

The hoses are routed internally in the loader body, also in other parts of the crane, where they are out of harm's way, thus reducing maintenance costs.

## Oil bath

On most Hiab cranes over 43,000 ft-lbs capacity, the slewing mechanism is enclosed in an oil bath. This keeps the slewing mechanism in great condition, year after year, ensuring that the crane can be used for extremely demanding applications in complete confidence.

### Hexagonal boom profile

The hexagonal profile ensures that the boom is always held in perfect balance, thanks to its shape and large support surface. The profile also minimizes boom deflection, thus reducing maintenance costs and increasing efficiency.



### JIC couplings

JIC couplings are standard on most Hiab cranes. They ensure easy and secure coupling, yet are very simple to disconnect for service.

### Large slide pads

The hexagonal profile enables the use of larger slide pads. This makes the extensions move more smoothly and reduces mechanical wear on the boom.

### Attachable tools

A wide range of attachable tools are available for your Hiab crane. These enable you to carry out many different tasks.

## CLX control system

The CLX control system gives you an excellent and versatile crane, providing all the functionality you need to perform a wide range of general cargo handling tasks. CLX cranes are controlled manually via side controls. The hydraulic system of a CLX crane features load-holding valves with an integrated hose failure function, as well as port relief valves to prevent the crane from overloading. The main control valve is the Hiab Valve 80, which enables the crane to perform more than one crane function at the same time, smoothly and efficiently.

## Valve 80

The Hiab Valve 80 is a top-of-the-line open-center valve based on a well-proven technique which gives superb reliability. It features very good dynamic characteristics and performs with ease while slewing and handling numerous operations at the same time. The valve can handle large oil flows, distributing great power to the cylinders and all other hydraulic functions, and yet it can be controlled with high precision.



### Valve 80

The Hiab Valve 80 is a top-of-the-line open-center valve, based on a well-proven technique which gives superb reliability. The valve handles large oil flows and provides great precision and ease of operation.



### Side controls

The levers are positioned at the crane base. Cross-controls give the same sequence of levers on both sides.

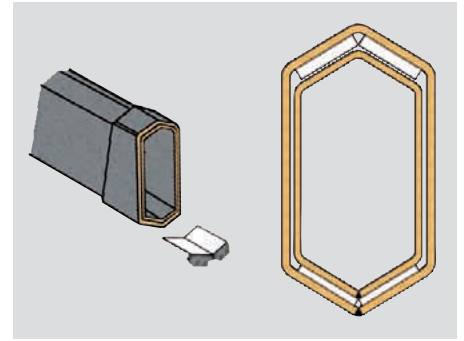

### Hexagonal boom profile

The hexagonal profile used on Hiab booms is a ground-breaking design introduced by Hiab many years ago. It is now standard throughout the market for loader cranes. Even the smallest Hiab crane takes advantage of this design.





**Calgary**

8019 - 54th Street S.E.  
Calgary AB T2C 4R7  
**1 (888) 843-6111**

**Edmonton**

9410 - 51 Avenue N.W.  
Edmonton, AB T6E 5A6  
**1 (866) 840-9365**

info@arwtruck.com    www.arwtruck.com